

# THE HVAC FACILITY CONNECTION

Volume 3, Issue 4  
Winter 2011

FOR COMFORT AND EFFICIENCY IN YOUR BUILDING

 **BRADY**



## Series R™ Helical Rotary Chiller

### Model RTWD



80 - 250 tons

Designed for higher efficiency using less refrigerant charge

Utilizing Variable Primary Flow and EarthWise™ will reduce the number of pumps and downsize portions of the HVAC system with no loss in performance.

Ideal replacement for older chillers with higher operating or maintenance costs.

Flexible- Perfect in almost any high performance system, including heat recovery, ice storage, dry cooler condensing or geothermal heating and cooling.

## Commercial Geothermal Is Heating Up!

### Geothermal Systems

The application of geothermal (ground-source) HVAC systems is growing rapidly in commercial markets. These systems offer premium efficiency because they use the relatively constant temperature of the earth to heat and cool. Energy removed from a building in the summer cooling season is sent to the earth and stored for retrieval during the winter heating season. Because the earth's temperature is generally more moderate than the outdoor air temperature, the annual energy efficiency is improved. In addition, the stored energy is effectively and efficiently recovered when heating is required.

A geothermal system consists of a ground-source loop coupled to the building's HVAC system to reject or add heat to the building as required. The ground-source loop can be in contact with:

- a large body of water (surface water heat pump),
- water pumped from the ground (ground water heat pump), or
- a closed-loop borefield of pipe buried in the ground (ground-coupled heat pump).

Traditionally, geothermal systems have been *distributed* systems. As the name suggests, a distributed geothermal system is one in which the equipment is distributed throughout the building. An example is a heat-pump system that uses small, unitary water-source heat pumps installed in or near each building space.

The efficiency of some geothermal heat-pump systems can be further enhanced by the recovery of heat within the building. If properly

configured, the energy removed by units cooling one part of the building is routed to units providing heat to other spaces. As HVAC designers know, the cheapest Btu to use for heating is the one already in the building.

Many building owners and HVAC designers hesitate when considering this multiple-unit, distributed system configuration because the maintenance required has to be performed in or near the occupied space. There are also the acoustic challenges of creating a quiet space with fans and compressors relatively near the occupied spaces.

With the advent of high-efficiency, higher-capacity chiller/heaters, a new class of geothermal systems is gaining momentum—the central geothermal system.

### Central Geothermal Systems

A key component of a central geothermal system is a chiller/heater. A chiller/heater is a heat-recovery chiller designed to efficiently provide condensing water at temperatures adequate for heating while simultaneously providing chilled water for cooling. The most sophisticated units can control unit capacity to either heating or cooling fluid temperature as required by the system mode of operation.

A central geothermal system (Figure 1) consists of one or more chiller/heaters, centrally located in a mechanical equipment room, coupled to a geothermal loop. The chiller/heaters provide heated and cooled fluid to hydronic heating and cooling air handlers throughout the building.

A central geothermal system includes:

- A geothermal loop for heat

Figure 1. Central geothermal system

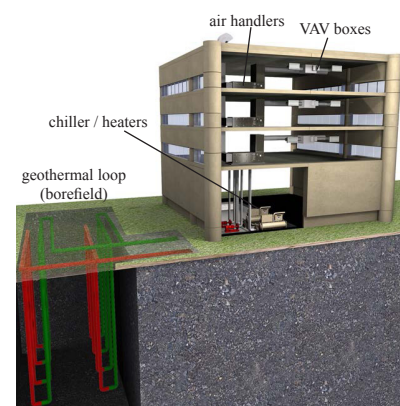

exchange with the earth.

- Central chiller/heater(s) to produce hot and cold water for heating and cooling.
- Air handlers, either centralized VAV, CV units or fan coil style.
- Controls programmed and commissioned for safe and efficient operation.
- Optional auxiliary heat source or auxiliary cooling rejection to create a “hybrid” system to optimize efficiency and life cycle cost.

### Advantages of a central system.

Compared to distributed heat-pump systems, central geothermal systems provide several benefits to the building owner and occupants.

**System efficiency.** Both central and distributed systems benefit from the relatively constant temperature of the earth for energy exchange. However, depending on the configuration, central geothermal systems recover building energy from cooling to heating potentially more efficiently than a distributed system. The unique central plant piping configuration provides sev-

eral operational and thermodynamic efficiency advantages compared to a system using distributed or water-to-water heat pumps. Effective heat recovery results in less ground-source fluid flow and therefore lower pumping energy and greater system efficiency.

**Maintenance.** Although the central system requires larger, commercial equipment, fewer compressors and fewer fans result in reduced maintenance. Because equipment is in a central location, maintenance, repair or replacement of HVAC equipment takes place outside of the occupied space. Building occupant safety is improved since maintenance items are not brought into the occupied space.

**Acoustics.** Central systems using chiller/heaters and air handlers have many options available for sound attenuation. In addition, locating the HVAC unit sound sources away from the space may have an immediate benefit to space acoustics.

**Airside options.** Because central geothermal systems enable the use of central air handlers, the advantages of fully integrated airside economizers, high-efficiency air filtration and other IAQ enhancing technologies can be applied.

#### Configuration.

There are basically three variations of central geothermal systems depending on the building load requirements.

Figure 2 provides a relative comparison of system sizing. Here are some general guidelines:

- For the smallest facilities, multiple water-to-water heat pumps may be applied.
- For medium buildings, a single chiller/heater may be appropriate.
- Larger installations may use multiple chiller/heaters. The multiple chiller/heater configuration offers a wider capacity range and the potential for

superior system efficiency because of the ability to cascade energy between cooling and heating loads.

This article will focus on the single chiller/heater geothermal system with four-pipe chilled-water/hot-water distribution to highlight characteristics of a central geothermal system.

#### Single Chiller/Heater Systems

The system configuration shown in Figure 3 uses a single chiller/heater to provide cooling and heating for a four-pipe, constant volume chilled-water/hot-water distribution system. This configuration allows for simultaneous building cooling and heating (or reheat) when required.

The key components of the system include:

- Chilled water/evaporator loop (blue)
- Heating water/condenser loop (red)
- Ground-source loop (green)
- Ground-source mode control valve
- Auxiliary heat source

*Note: Not all central geothermal systems require an auxiliary heat source. However, in the case of a single unit system, it is often prudent to include at least one as an emergency source of heat in the event of a system component failure.*

**Loop configuration.** The chilled-water and hot-water distribution loops may be configured as constant volume (shown in Figure 3) or variable flow (primary/secondary or variable primary). Figures 4-6 show primary/secondary heating and variable primary flow for cooling. The design provides flexibility to choose the best option for temperature and flow requirements while considering the limitations of system components. It's particularly important to consider the chiller/heater design flow

Figure 3. Single chiller, four-pipe, constant-volume system components.

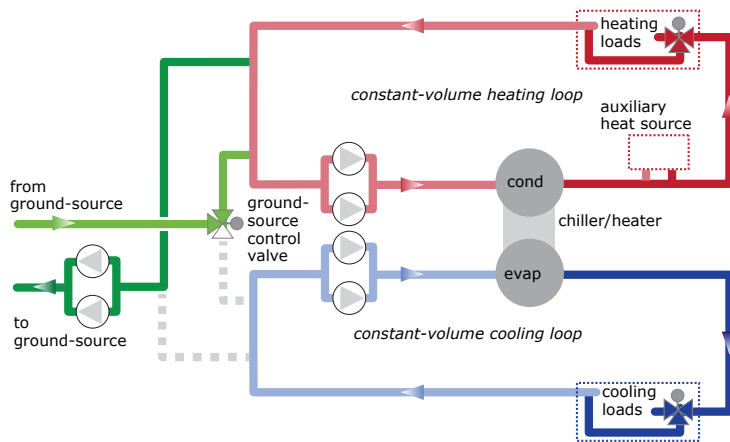
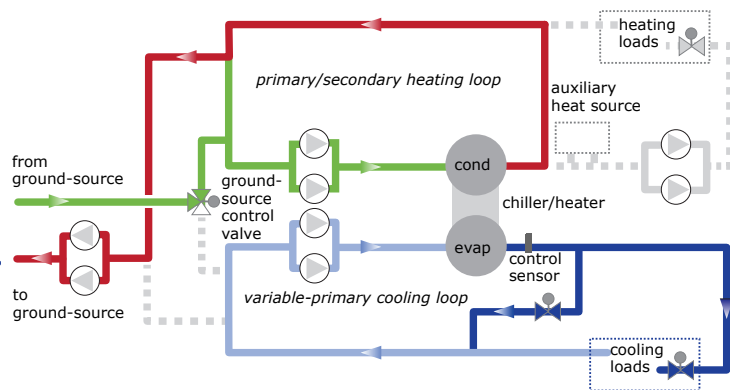

Figure 4. Cooling-only mode of operation



rates and allowable operating flow range when selecting the distribution loop configurations.

#### System modes of operation.

The system operates in three basic modes: cooling only, heating only and simultaneous cooling/heating.

**Cooling-only mode.** In the cooling-only mode (Figure 4), the chilled-water/evaporator loop operates as a normal cooling system with the chiller/heater controlling its compressor loading based on its leaving-chilled-water temperature.

Heating is not required, so the heating water/condenser loop is used to transfer energy from the chiller/heater condenser to the ground-source loop.

From the ground-source loop, the two-position control valve directs water flow to the condenser loop. The ground-source loop pump is controlled to reject the chiller/heater condenser heat to be absorbed by the ground-source.

**Heating-only mode.** In the heating-only mode (Figure 5), the function of the loops is reversed. The heating loop operates to meet the heating

load and the chiller/heater capacity is controlled based on the heating loop temperature.

The chilled water/evaporator loop transfers energy from the ground-source loop to the chiller/heater evaporator.

From the ground-source loop, the control valve directs water flow to the evaporator loop. The ground-source loop pump is controlled to supply energy to the chiller/heater evaporator. The auxiliary heat source is activated only in the event that the ground-source system cannot meet the heating load.

#### Simultaneous cooling/heating.

When the building requires both heating and cooling, it can be either cooling dominant or heating dominant.

The system is defined as cooling dominant when the building's cooling load (plus compressor cooling energy) is greater than the required heating load (Figure 6). The excess energy not required to heat the building is rejected to the ground-source. The chilled-water loop acts similarly to the cooling-only mode with the exception that the heating

Figure 2. Geothermal system capacity range comparison

System type	Capacity range
Distributed heat pump system	2-150 tons
Single chiller / heater	60-200 tons
Multiple chiller / heaters	120-1500 tons

loop is controlled to meet the building's heating temperature requirement by modulating the ground-source water flow.

The system is defined as heating dominant when the building's net heating load is greater than the cooling load (plus compressor cooling energy) energy rejection. The heating water loop operates with the chiller/heater in the heating mode controlling to its leaving-condenser-water temperature. Extra energy required to meet the building's heating load is injected into the chilled-water loop from the ground-source, similar to the heating-only mode. The chilled-water loop is controlled to meet the building's cooling temperature requirement by modulating the ground-source water flow. If the building's cooling load, plus ground-source energy, plus chiller/heater compressor energy cannot meet the building's heating load, the auxiliary heat is brought on to supplement the heating capacity.

Switch over between dominant modes is initiated based on temperature trends in each loop.

### Keys to Successful Central Geothermal System Design and Operation

While not overly complex, central geothermal systems demand careful planning for design and commissioning. Based on several years of experience, the following should be considered for successful implementation.

**Building load analysis.** There is nothing more important than an accurate load analysis for a successful geothermal system, performed with a comprehensive energy modeling program. Proper load analysis is critical and may even reveal if the job could benefit from a hybrid system (see side bar Geothermal or Hybrid Geothermal?). Using the building energy profile data as well as test data from on-site sample test bores, a certified GeoExchange Designer can use design programs to properly size the central plant, borefield and hybrid devices.

**Borefield sizing.** The most important and costly part of a geothermal system is the ground-source. If oversized, the ground-source can be prohibitively costly and cause owners to abandon the thought of a geothermal system. As with any HVAC system, oversizing not only wastes first cost but results in inef-

Figure 5. Heating-only mode of operation

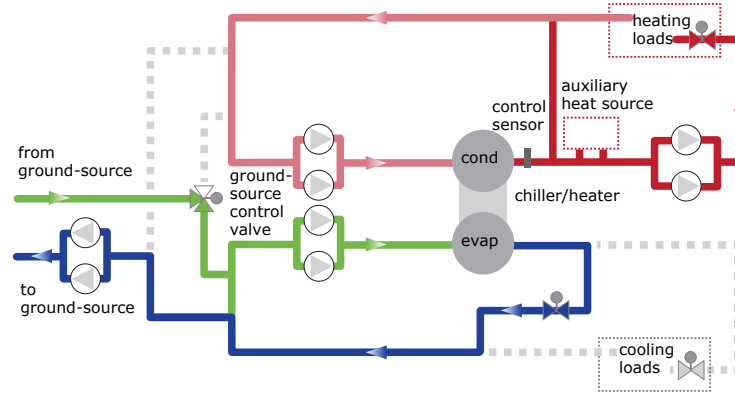
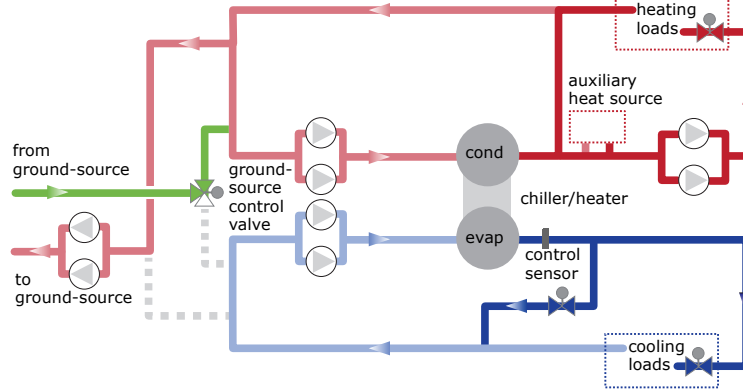

Figure 6. Cooling dominant simultaneous cooling / heating operation



ficient operation and poor reliability for the life of the system.

On the flip side, an undersized groundsource can result in eventual system non-operation. If the ground-source heat transfer capability is too low, the temperature it provides to the system will rise or fall over time. After several years of operation, this can potentially lead to the ground-source becoming an ineffective energy sink/source.

The International Ground Source Heat Pump Association (IGSHPA) recommends that 20-year borefield models be conducted to determine borefield sizing.

**Equipment selection.** Geothermal systems are at their heart heat recovery systems. As such these refrigeration systems often operate at extreme conditions—low evaporator temperatures and high condenser temperatures. This subjects the unit components (particularly the compressors) to pressures and temperatures not typically seen in standard chilled-water HVAC systems. Therefore it's critical that the equipment applied in these systems is fully qualified for long-term operation under such conditions.

In addition, equipment with advanced control capabilities can

greatly improve system control and reliability. Consider equipment with capacity control based on leaving- evaporator or condenser water temperature; the ability to switch between the two seamlessly without shutting down the unit; and adaptive control to limit chiller/heater operation during unacceptable conditions that might otherwise cause a control safety lockout while enabling the unit to produce the maximum possible capacity.

**System design.** Central geothermal systems are relatively new to the market; as such vendor and contractor experience is limited. It's important for the engineer to evaluate the system in all operating modes and specify the system layout, equipment requirements and controls sequence of operation and commissioning thoroughly. Items to consider include minimum and maximum allowed operating temperatures and flows; system loads: peak cooling, peak heating, and peak coincident cooling and heating; as well as maximum and minimum ground-source temperatures and flows, among others.

**Controls.** The successful and sustainable operation of any geothermal system hinges on the proper operation of the system controls. Today, most local control vendors

### Geothermal or Hybrid Geothermal?

A common misconception is that a borefield can serve as an "infinite energy source" and/or "infinite energy sink." While the earth as a whole may effectively be an infinite source or sink, the relatively poor heat transfer characteristics of the ground means an isolated borefield is not.

A borefield's ability for short term and seasonal heat transfer is limited. As a result, an excessively large ground-source installation may be required to meet the needs of a building with very high daily or weekly peak loads or with very unbalanced seasonal loads. The implication of excessive sizing is unacceptable first and life cycle cost.

Commercial buildings with high internal loads can exhibit extreme short term peaks and seasonal load imbalances. A load analysis on one commercial building that was a candidate for a geothermal system revealed that the cooling energy rejected to the ground-source would be over 26 times the energy extracted for heating on an annual basis. The size and price of a ground-coupled system to serve this load profile would surely be out of the budget for most owners.

Is there a way to achieve the efficiency of a geothermal system for buildings with unattractive load profiles at a reasonable cost? The answer is often YES! Combining a ground-source system with an auxiliary heat rejecter (evaporative cooler or dry cooler) for cooling dominant systems or an auxiliary heat source (boiler or solar thermal) for heating dominant systems can significantly reduce first cost, improve life cycle cost and if controlled effectively, raise system operating efficiency.

If you encounter a geothermal system that is out of budget because of the ground-source size, review the building load profile to determine if the job may benefit from a hybrid configuration.



Receive this newsletter  
by email:  
Send an email to  
[info@bradyservices.com](mailto:info@bradyservices.com)

**New application manuals  
now available**

**Central Geothermal Systems,**  
(SYS-APM009-EN, Feb 2011)

**Chilled-Water VAV Systems,**  
(SYS-APM008-EN, Aug 2009)

**Chiller System Design and  
Control.**  
(SYS-APM001-EN, May 2009)

Visit [www.trane.com/bookstore](http://www.trane.com/bookstore) to  
order and view a complete list of  
resources.

are unfamiliar with the required sequences or the safe operating limits of specific manufacturers units. Also, it is virtually impossible to manually operate one of these systems. For these reasons, thoroughly documented control requirements and sequence of operation is critical.

**Economics.** The significant first cost of geothermal systems obligates the project team to look for alternate sources of payback. Fortunately there are numerous federal, state and utility incentives for geothermal systems. A great starting point for incentive resources is [www.dsireusa.org](http://www.dsireusa.org).

In October 2008, geothermal systems were added to the definition of “energy property” in the Internal Revenue Code, providing a 10 percent tax credit for equipment placed in service through the end of 2016. “Energy property” is classified as a five-year depreciable property in the Internal Revenue Code meaning the cost of the property can be deducted on a Modified Accelerated Cost Recovery System (MACRS) basis. Contact your local tax professional to see if you satisfy the tax code

rules and qualify for these and other tax benefits.

**A Final Thought...**

Many of the chiller/heater manufacturers not only offer the refrigeration units for central geothermal systems but whole factory-fabricated and tested central geothermal plants. The number of heating/cooling units and their capacities, the system operating temperatures and the required pump pressures and system flows can be specified, and a complete factory-tested system arrives on the jobsite several weeks later. The assured performance and reduced risk of this approach may be a consideration for an owner that is new to the central geothermal cooling and heating concept.

By Lee Cline, systems engineer and Jeanne Harshaw, program manager, both of Trane.

**Resources**

Database of State Incentives for Renewable Energy & Efficiency  
[www.dsireusa.org](http://www.dsireusa.org)

International Ground Source Heat Pump Association (IGSHPA)  
[www.igsHPA.okstate.edu](http://www.igsHPA.okstate.edu)

Trane Central Geothermal Systems application manual (SYS-APM009-EN) to order visit  
[www.trane.com/bookstore](http://www.trane.com/bookstore)

Trane Engineers Newsletter LIVE program “Central Geothermal System Design and Control,” available on-demand at  
[www.trane.com/continuingeducation](http://www.trane.com/continuingeducation)

TRACE™ 700 energy and economic analysis program. More information and trial software available at  
[www.trane.com/TRACE](http://www.trane.com/TRACE)



PO Box 13587  
Greensboro, NC 27415  
[www.bradyservices.com](http://www.bradyservices.com)

[newsletter input / feedback and address changes](#)

**Prefer to receive the newsletter by email? Let us know!**

fax: (336) 378-0677 email: [info@bradyservices.com](mailto:info@bradyservices.com)